

Application: fiberglass, composite materials and other.  
Assembly: bonding, lamination, moulding.

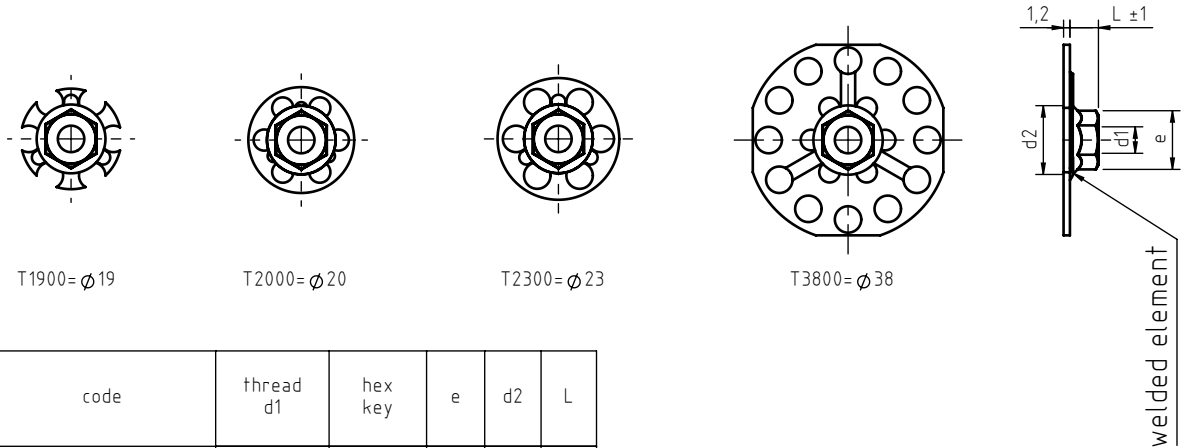

code	thread d1	hex key	e	d2	L
DFP04T1900040.---	M 4	7	9,1	7,8	4,3
DFP04T2000040.---					
DFP04T2300040.---					
DFP04T3800040.---					
DFP05T1900050.---	M 5	8	10,5	8,9	4,8
DFP05T2000050.---					
DFP05T2300050.---					
DFP05T3800050.---					
DFP06T1900060.---	M 6	10	12,95	11,1	5,4
DFP06T2000060.---					
DFP06T2300060.---					
DFP06T3800060.---					

Non binding dimensions, expressed in mm.

Standard
  On demand
  Not manufactured

Material: steel \_\_\_\_\_,12, stainless steel AISI 316 \_\_\_\_\_,51  
 Finishing: nuts in steel: zinc coated  
 nuts in stainless steel AISI 316: natural  
 Tolerance: where not specified, coarse degree of accuracy,  
 according to ISO 2768-m  
 Thread: metric ISO 6 H  
 Example: flanged threaded nut with T2300 round through hole plate, M5  
 thread, 4,8 mm height, zinc plated steel:

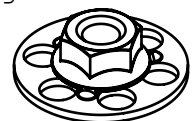

DFP05T2300050.12

Headquarter and Export department:  
 Via Montalcone 144 - 10136 - Turin - IT - Tel. +39.011.700301 - Fax +39.011.702947  
 Milan branch:  
 Via E. Cialdini 37 - 20161 - Milan - IT - Tel. +39.02.646.8476 - Fax +39.02.662.00275  
 Production and purchase departments:  
 Via E. Pavanello 1 - 30030 - Maerne di Martellago (Venice) - IT - Tel. +39.041.503.0100  
 Fax +39.041.503.0110

SPECIALINSERT® COMMITS ITSELF TO CONTINUOUSLY IMPROVE ITS PRODUCTS. IT RESERVES THE RIGHT TO CHANGE THEIR TECHNICAL AND STRUCTURAL CHARACTERISTICS WITHOUT PRIOR NOTICE. ALL RIGHTS ARE RESERVED AND THE DUPLICATION, EVEN PARTIAL, OF THESE DOCUMENTS AS WELL AS ITS DISTRIBUTION TO THIRD PARTIES ARE FORBIDDEN, UNLESS OTHERWISE AND EXPRESSLY AUTHORIZED BY SPECIALINSERT.

Application: fiberglass, composite materials and other.  
Assembly: bonding, lamination, moulding.

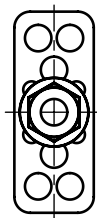

R3815=38x15

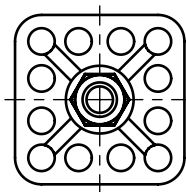

Q3232=32x32

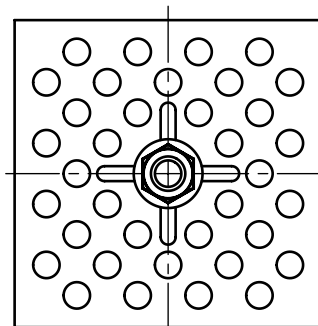

Q5858=58x58

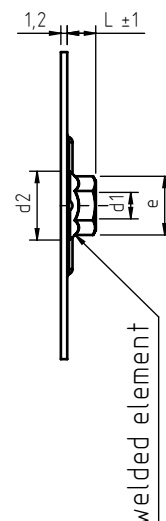

code	thread d1	hex key	e	d2	L
DFP04R3815040. _ _	M 4	7	9,1	7,8	4,3
DFP04Q3232040. _ _					
DFP04Q5858040. _ _					
DFP05R3815050. _ _	M 5	8	10,5	8,9	4,8
DFP05Q3232050. _ _					
DFP05Q5858050. _ _					
DFP06R3815060. _ _	M 6	10	12,95	11,1	5,4
DFP06Q3232060. _ _					
DFP06Q5858060. _ _					

Non binding dimensions, expressed in mm.



Standard



On demand



Not manufactured

Material: steel \_\_\_\_\_,12, stainless steel AISI 316 \_\_\_\_\_,51

Finishing: nuts in steel: zinc coated  
nuts in stainless steel AISI 316: natural

Tolerance: where not specified, coarse degree of accuracy,  
according to ISO 2768-m

Thread: metric ISO 6 H

Example: flanged threaded nut with R3815 rectangular through hole plate, M6  
thread, 5,4 mm height, zinc plated steel:

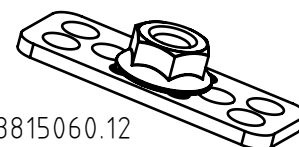

DFP06R3815060.12

Headquarter and Export department:  
Via Monfalcone 144 - 10136 - Turin - IT - Tel. +39.011.700301 - Fax +39.011.702947  
Milan branch:  
Via E.Cialdini 37 - 20161 - Milan - IT - Tel. +39.02.646.8476 - Fax +39.02.662.00275  
Production and purchase departments:  
Via E. Pavanello 1 - 30030 - Maerne di Martellago (Venice) - IT - Tel. +39.041.503.0100  
Fax +39.041.503.0110

Application: silicone plugs resistant up to 315°C, ideal for the protection of through holes, thanks also to the handle that allows easy extraction. Reusable.

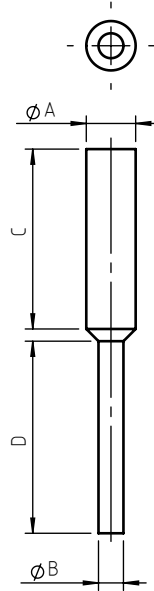

code	For thread	A	B	C	D
MP/CPP20	M4	3,96	1,57	15,88	19,05
MP/CPP23	M5	4,80	3,10	32,10	30,25
MP/CPP37	M6	5,40	3,00	31,25	29,70
MP/CPP42	M8	7,20	3,50	25,15	25,60
MP/CPP50	M10	8,80	4,75	31,19	28,75

Non binding dimensions, expressed in mm.

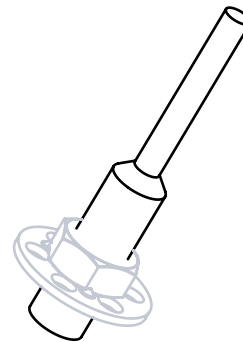

Headquarter and Export department:  
Via Monfalcone 144 - 10136 - Turin - IT - Tel. +39.011.700301 - Fax +39.011.702947  
Milan branch:  
Via E. Cialdini 37 - 20161 - Milan - IT - Tel. +39.02.646.8476 - Fax +39.02.662.00275  
Production and purchase departments:  
Via E. Pavanello 1 - 30030 - Maerne di Martellago (Venice) - IT - Tel. +39.041.503.0100  
Fax +39.041.503.0110

SPECIAL INSERT® COMMITS ITSELF TO CONTINUOUSLY IMPROVE ITS PRODUCTS. IT RESERVES THE RIGHT TO CHANGE THEIR TECHNICAL AND STRUCTURAL CHARACTERISTICS WITHOUT PRIOR NOTICE. ALL RIGHTS ARE RESERVED AND THE DUPLICATION, EVEN PARTIAL, OF THESE DOCUMENTS, AS WELL AS ITS DISTRIBUTION TO THIRD PARTIES, ARE FORBIDDEN, UNLESS OTHERWISE AND EXPRESSLY AUTHORIZED BY SPECIAL INSERT.