

Application: fiberglass, composite materials and other.
Assembly: bonding, lamination, moulding.

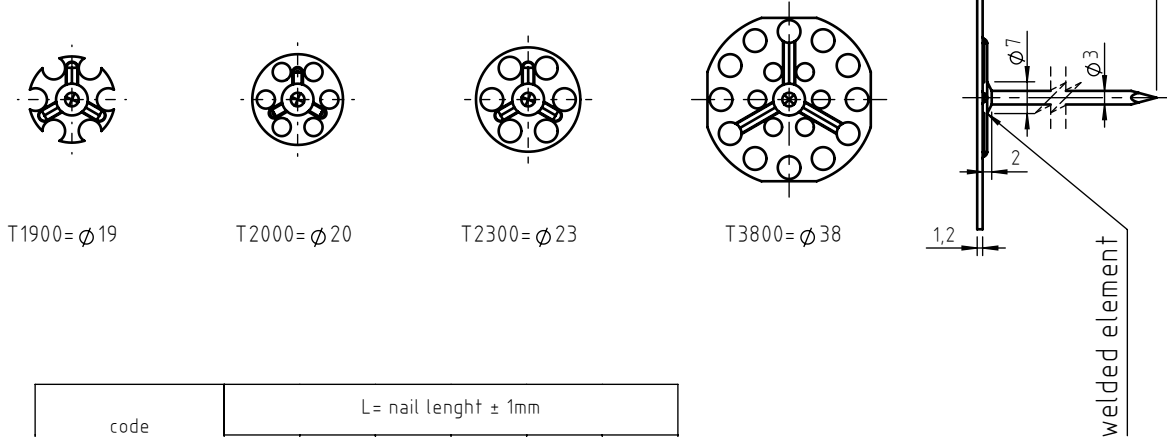

code	L = nail length ± 1mm					
	50	60	70	80	90	100
CR_T1900030_						
CR_T2000030_						
CR_T2300030_						
CR_T3800030_						

Non binding dimensions, expressed in mm.

Other details and materials on demand.

Standard
 On demand
 Not manufactured

Material: steel _____,12, acciaio inox AISI 316 _____,51

Finishing: steel nail: zinc coated
stainless steel nail AISI 316: natural

Tolerance: where not specified, coarse degree of accuracy,
according to ISO 2768-m

Example of designation: nail with round plate Y2300, length 70 mm,
stainless steel AISI 316:

CR70T2300030.12

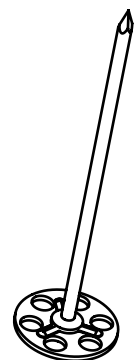

Headquarter and Export department:
 Via Monfalcone 144 - 10136 - Turin - IT - Tel. +39.011.700301 - Fax +39.011.702947
 Milan branch:
 Via E. Cialdini 37 - 20161 - Milan - IT - Tel. +39.02.646.8476 - Fax +39.02.662.00275
 Production and purchase departments:
 Via E. Pavanello 1 - 30030 - Maerne di Martellago (Venice) - IT - Tel. +39.041.503.0100
 Fax +39.041.503.0110

SPECIALINSERT® COMMITS ITSELF TO CONTINUOUSLY IMPROVE ITS PRODUCTS. IT RESERVES THE RIGHT TO CHANGE THEIR TECHNICAL AND STRUCTURAL CHARACTERISTICS WITHOUT PRIOR NOTICE. ALL RIGHTS ARE RESERVED AND THE DUPLICATION, EVEN PARTIAL, OF THESE DOCUMENTS, AS WELL AS ITS DISTRIBUTION TO THIRD PARTIES ARE FORBIDDEN, UNLESS OTHERWISE AND EXPRESSLY AUTHORIZED BY SPECIALINSERT.

Application: fiberglass, composite materials and other.
 Assembly: bonding, lamination, moulding.



Q1515=15x15

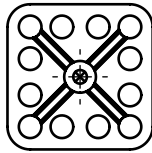

Q3232=32x32



R3815=38x15

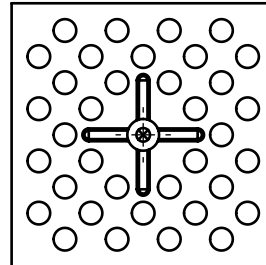

Q5858=58x58

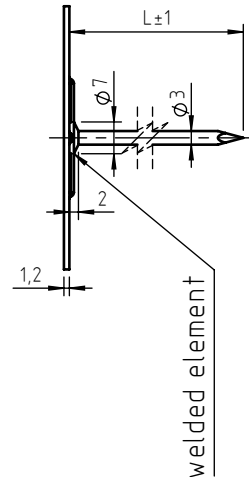

code	L = nail length ± 1mm					
	50	60	70	80	90	100
CR_Q1515030_						
CR_Q3232030_						
CR_R3815030_						
CR_Q5858030_						

Non binding dimensions, expressed in mm.

Other details and materials on demand.

Standard
 On demand
 Not manufactured

Material: steel _____,12, acciaio inox AISI 316 _____,51
 Finishing: steel nail: zinc coated
 stainless steel nail AISI 316: natural

Tolerance: where not specified, coarse degree of accuracy,
 according to ISO 2768-m

Example of designation: nail with square plate Y5858, length 70 mm,
 galvanized steel AISI 316

CR70Q5858030.12

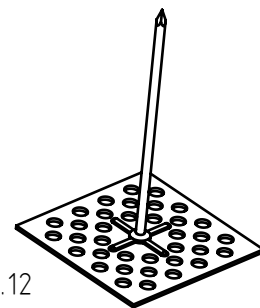

Application: silicone plugs resistant up to 315°C, ideal for the protection of through holes, thanks also to the handle that allows easy extraction. Reusable.

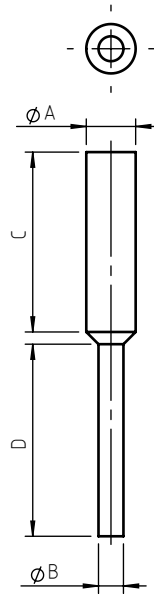

code	For thread	A	B	C	D	color
MP/CPP20	M4	3,96	1,57	15,88	19,05	Pink
MP/CPP23	M5	4,95	2,79	25,40	25,40	Light Green
MP/CPP37	M6	6,53	3,30	25,40	25,40	Blue
MP/CPP42	M8	7,92	3,73	25,40	25,40	Green
MP/CPP50	M10	9,53	3,99	25,40	25,40	Grey

Non binding dimensions, expressed in mm.

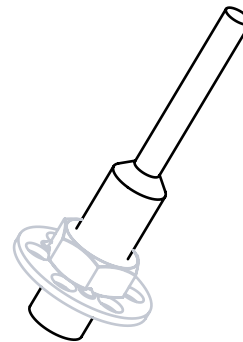

Headquarter and Export department:
Via Monfalcone 144 - 10136 - Turin - IT - Tel. +39.011.700301 - Fax +39.011.702947
Milan branch:
Via E. Cialdini 37 - 20161 - Milan - IT - Tel. +39.02.646.8476 - Fax +39.02.662.00275
Production and purchase departments:
Via E. Pavanello 1 - 30030 - Maerne di Martellago (Venice) - IT - Tel. +39.041.503.0100
Fax +39.041.503.0110