

Application: metal and not metal sheets.  
Assembly: with special hand or pneumatic tools.

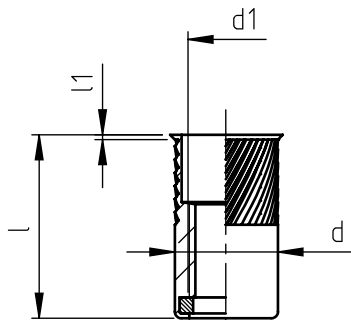

Picture A

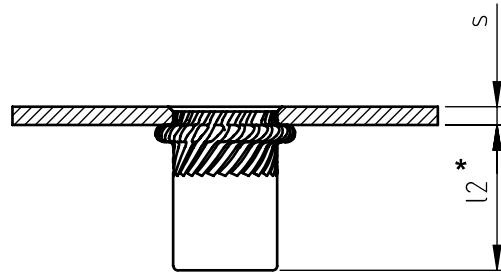
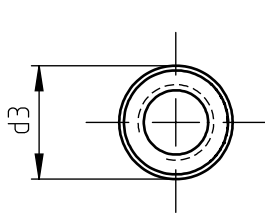
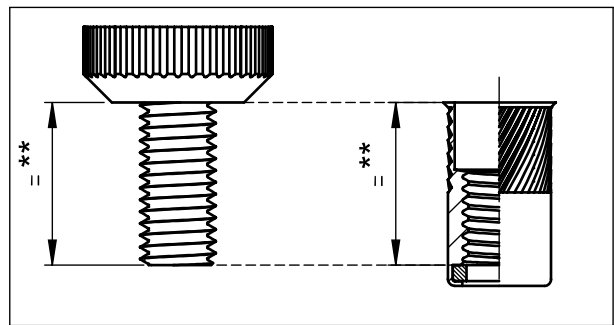

code	s	l +0,50 -0,50	d1 6H	d	d3	l1 ~	d5 +0,15 0	l2 *
TFM/A M 5/8ZI	0,5 ÷ 2,5	14,0	M 5	7	8	0,6	7	12
TFM/A/L M 5/8ZI	2,5 ÷ 4,5	16,0						
TFM/A M 6/8ZI	0,5 ÷ 3,0	16,0	M 6	9	10	0,6	9	14
TFM/A/L M 6/8ZI	3,0 ÷ 5,5	18,5						
TFM/A M 8/8ZI	0,5 ÷ 3,5	18,0	M 8	11	12	0,6	11	14
TFM/A/L M 8/8ZI	3,5 ÷ 6,0	20,5						
TFM/A M10/8ZI	0,5 ÷ 3,5	23,5	M10	13	14,5	0,85	13	17
TFM/A/L M10/8ZI	3,5 ÷ 6,0	26,0						

Non binding dimensions, expressed in mm.

\* Dimension determined from the average of the grip "s" min and max values.

\*\* The insert has to be screwed on the mandrel for the whole threaded length, avoiding the screw into the nylon washer as highlighted in the picture (A) above.



Standard



On demand



Not manufactured

Material: blind thread nut steel no.1.0718

washer nylon

Finishing: blind thread nut zinc-plated

washer natural

Thread: ISO 6 H metric

Example: thread tubular self-locking rivet nut,  
low profile head, knurled shank, steel,  
grip 3,0 mm, M 8 thread: TFM/A M 8/8ZI

