

Applications: sheet metal, stainless steel, light alloy, non-ferrous sheet metal.  
Assembly: by pressure.

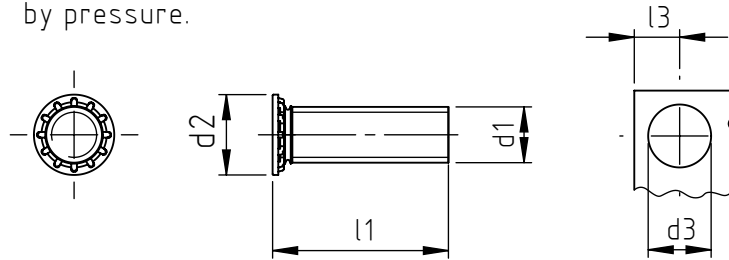

code	stud length l1 ±0,4	available					
		M2,5	M3	M4	M5	M6	M8
506	6,0	X	X	X	X		
508	8,0	X	X	X	X	X	
510	10,0	X	X	X	X	X	X
515	15,0	X	X	X	X	X	X
520	20,0	X	X	X	X	X	X
525	25,0	X	X	X	X	X	X
530	30,0			X	X	X	X
534	34,0			X	X	X	X

code	metric thread d1	sheet thickness ≥ *	d2	hole diameter d3 0/+0,05	distance from the edge (min.) ≥L3
0 025	M2,5	1,0	4,0	2,5	5,0
0 030	M3	1,0	4,6	3,0	5,5
0 040	M4	1,0	5,9	4,0	7,0
0 050	M5	1,0	6,5	5,0	7,5
0 060	M6	1,5	8,5	6,0	8,0
0 080	M8	1,5	10,0	8,0	10,0

\* When sheet thicknesses is lower than 1,0 mm, use press studs for thin sheets, the code is:   2  . (special part on demand)

Non binding dimensions, expressed in mm.

Standard       On demand

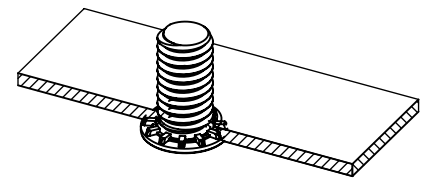

Material: steel, stainless steel  
Finishing: steel: zinc-plated (on 80 HRB max)  
                  stainless steel: natural (on 70 HRB max) (on demand)  
Tolerance: where not specified, degree of accuracy (coarse)  
                  according to ISO 2768 - m  
Thread d1: metric ISO 6g  
Example: Clifa® self clinching stud, M 5 thread,  
                  stud length L=16 mm, zinc-plated steel: 516 0 050.12

\_\_\_\_\_ .12  
\_\_\_\_\_ .50

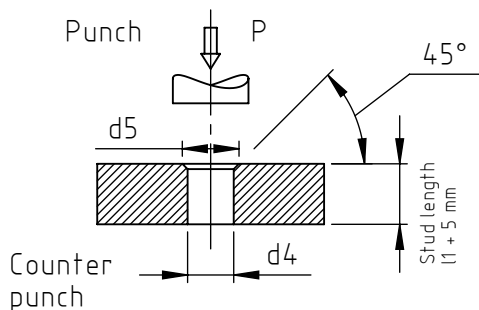

clifa®	counter punch hole diameter d4	flare diameter d5	approx. pressure required on sheets P(KN)
M2,5	2,6	3,4	8,9 ÷ 12
M3	3,1	4,0	10,5 ÷ 19
M4	4,1	5,2	16 ÷ 25
M5	5,1	6,4	29 ÷ 35
M6	6,1	7,6	30 ÷ 50
M8	8,1	10,2	30 ÷ 60

Note: pressure value depends on Clifa® size, teeth type, and application.  
Clifa stud must be inserted flush to the sheet metal surface. Avoid any over-pressure.  
It is advisable to carry out some preliminary tests in order to determine the best assembly.

Headquarter and Export department:  
Via Montfalcone 144 - 10136 - Torino - IT - Tel. +39.011.700301 - Fax +39.011.702947  
Milan branch:  
Via E. Cialdini 37 - 20126 - Milano - IT - Tel. +39.02.646.8476 - Fax +39.02.662.00275  
Production and purchase departments:  
Via E. Pavanello 1 - 30030 - Maerne di Martellago (Venezia) - IT - Tel. +39.041.503.0100  
Fax +39.041.503.0110